

SECCIÓN A-A
Esc.1:50

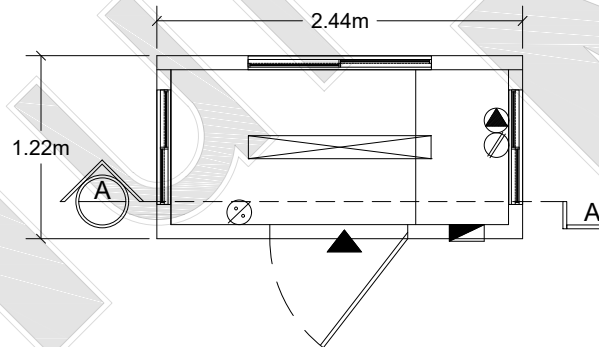

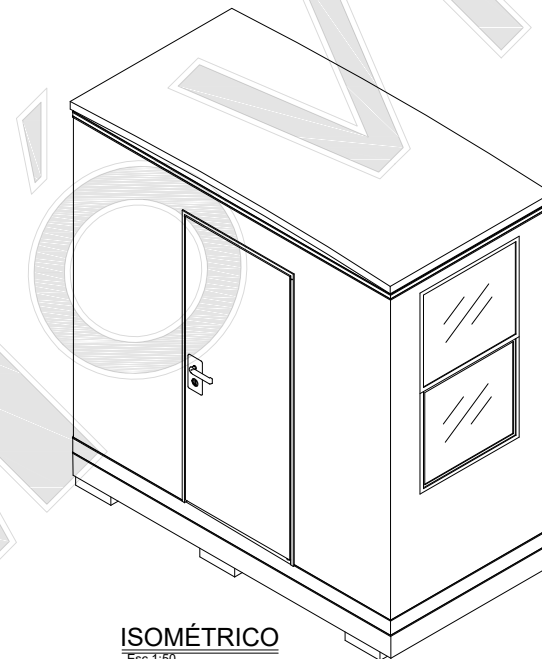





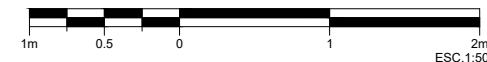

MM48
Esc.1:50



ISOMÉTRICO
Esc.1:50



ACABADOS	EQUIPO	PUERTAS	SIMBOLOGÍA	 <small>RENTA Y VENTA DE ESPACIOS MÓVILES</small> <small>Av. San Antonio No. 303 Torre 1 Piso 1 Col. Tlalpan San Ángel 01090 Álvaro Obregón, D.F.</small> <small>Tel. (55) 5616450-71 www.multimovil.com.mx</small>
PARED EXTERIOR: CUBIERTA DE ACERO	ESCRITORIO (1)	PUERTA EXTERIOR 36"X 80" (1)	LÁMPARA DE CANAL 	
PARED INTERIOR: PANEL DE VINIL			FOCO INCANDESCENTE 	
PISO: LOSETA VINILICA			APAGADOR SENCILLO 	
TECHO EXT.: LAMINA GALVANIZADA		VENTANAS	CONTACTO ELÉCTRICO 	
TECHO INT: TABLA ROCA		ALUMINIO 46" X27" (1)	CONTACTO AIRE ACOND. 	
		ALUMINIO 30" X53" (2)	SALIDA VOZ Y DATOS 	
			EXTRACTOR 	
			CENTRO DE CARGAS 	
				Esc. 1:50
				MM84
				Formato:11"x8.5"